

*the self-contained automatic lubricator  
that lives up to its name*

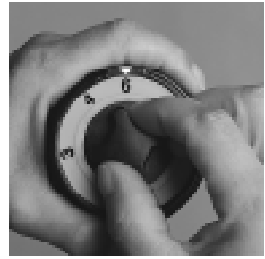

**GREASOMATIC®**

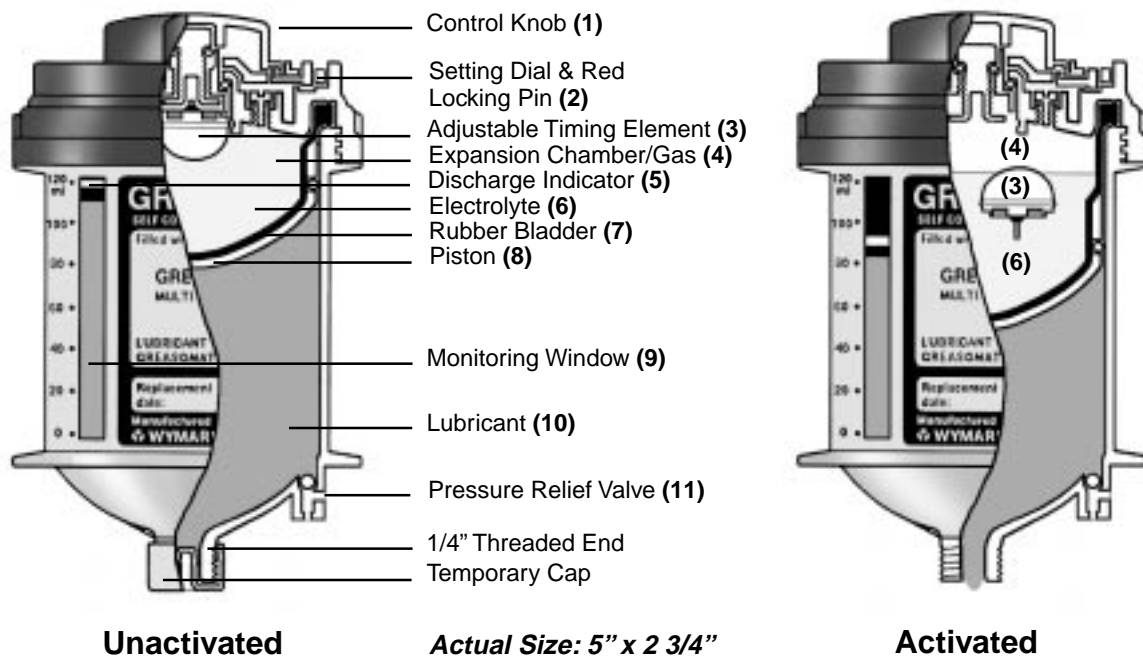

## TECHNICAL INFORMATION • • •

The GREASOMATIC is a completely self-contained single point automatic lubricator. When activated and installed it discharges 120 ml of lubricant at a preselected, controlled rate over a period of one to twelve months. The GREASOMATIC has seven built-in discharge rates making it ideal for a wide variety of applications. The lubricator is constructed of corrosion proof plastic making it suitable for use in demanding or harsh environments as well as those having hygienic requirements. The lubricant flow can be easily monitored using the discharge indicator visible through the three translucent windows in the body.

### OPERATION

The principle of operation is based on a controlled galvanic chemical reaction which generates a gas. The unique adjustable galvanic timing element (3) is built into the GREASOMATIC. When the unit is activated, the element is introduced into a mildly acidic liquid electrolyte (6) starting the chemical reaction. As the gas is generated in the expansion chamber (4), it slowly expands

the rubber bladder (7) which pushes against the piston (8). The movement of the piston extrudes the lubricant (10) into the bearing at a controlled rate. The electrolyte and gas remain hermetically sealed within the expansion chamber preventing contamination of the lubricant or the environment.

### DISCHARGE CONTROL

The discharge duration depends on the rate of gas generation and is governed by the configuration of the galvanic timing element. Before activation, the adjustable timing element is connected to the underside of the control knob (1). Turning the control knob *clockwise* until the arrow points to the desired discharge period adjusts the galvanic timing element to the selected discharge rate. If the knob is accidentally turned beyond the chosen setting, it can be reset by rotating the dial completely *counterclockwise* back to zero and then resetting the correct time period. The seven available settings are 1, 2, 3, 4, 6, 8 and 12 indicating the discharge durations in months of a GREASOMATIC operating in

an average ambient temperature of 68°F (20°C). For additional discharge rates at higher or lower temperatures consult the Discharge Rate Chart.

### **ACTIVATION**

After the discharge rate setting has been made, the red locking pin (2) is depressed. At this point the time period is established and cannot be changed. The continued *clockwise* rotation of the control knob for 10 to 12 turns (until the control knob spins freely and a clicking sound is heard) causes the adjustable timing element to be ejected into the electrolyte. This starts the gas generating reaction and the resulting pressure build up. The longer discharge settings, such as 6, 8 and 12 months, require more time for adequate pressure to develop. For this reason, a GREASOMATIC used in applications which require immediate lubricant supply should be activated far enough in advance of installation to allow a sufficient flow of lubricant to develop.

### **INSTALLATION**

A new installation requires the removal of the bearing's grease fitting and replacement with the activated GREASOMATIC. Use an adapter if the grease fitting is other than 1/4". The lubricator may be remotely installed up to distances of 6 feet for convenience or to protect the unit from temperature extremes. To insure a free flow of lubricant to the bearing the remote line *must have a minimum of 1/4" ID with 3/8" preferable*. Tight bends and fittings with small diameters should be avoided. If this is not possible, compensate by choosing a shorter time setting. The bearing and lube lines should be purged and pre-charged with the same grease contained in the lubricator before installing it hand tight. Two or more lubricators may be installed on one bearing when a larger supply of lubricant is required, but one lubricator should *never* be used to supply grease to more than one bearing. It is important not to remove or loosen the lubricator until it is scheduled to be replaced. Doing so can cause the generated pressure to be lost and the lubricator's working life

substantially reduced. The constant slow feeding of lubricant at low pressures creates a purging action which makes the **GREASOMATIC** ideal for installation on bearings in extremely dirty environments or immersed in liquids. They may be used on rotating or moving equipment. Grease filled lubricators can be installed with the outlet in any position.

### **OIL FILLED LUBRICATORS**

To prevent the uncontrolled discharge of lubricant from oil filled lubricators there are two choices for installation. 1. The lubricator can be mounted with the outlet in an upright position with a remote line to the bearing. 2. The unit can be installed in any position using a non-return check valve at the bearing. The oil filled GREASOMATIC also provides a simple solution to many chain lubrication problems.

### **MONITORING**

During the working life of the lubricator the discharge indicator (5) is clearly visible through the three monitoring windows (9) in the body of the unit. This makes checking the progress of the lubricator simple. On an initial installation it is advisable to monitor the bearing frequently to assure a proper rate setting has been selected.

### **OPERATING PRESSURES**

Under normal conditions the lubricator operates at a pressure of less than 20 PSI. The operating pressure is influenced by the resistance to lubricant flow in the bearing and remote line. If there is a blockage in the bearing or lube line, the GREASOMATIC will build up pressure causing the pressure relief valve (11) to open releasing lubricant. This is a safety measure to prevent over pressurization and also to serve as a warning that no lubricant is reaching the bearing.

### **LUBRICANT FILLS**

The capacity of the GREASOMATIC is 120 ml or approximately 96 grease gun strokes. They are available with a wide variety of lubricant fills. Liquid lubricants present no problem but under the sustained light pressure

of the lubricator many greases suffer from oil-soap separation. This causes “soap plugs” to develop and curtails the flow of lubricant to the bearing. Selection of a grease should take into consideration this separation factor as well as the lubrication requirements of the bearing. WYMARK’s Multipurpose Grease L has been specially formulated to resist separation when used in the GREASOMATIC. Please consult your sales representative regarding other preferred greases for use in the lubricator.

**EXTREME TEMPERATURES**

The ambient temperature, not the bearing temperature, controls the rate of the chemical reaction within the lubricator. As with all chemical reactions, the higher the

temperature the faster the reaction and lower temperatures slow it down. The GREASOMATIC can be installed in any ambient temperature between -4°F (-20°C) and +140°F (60°C). If the lubricator is to operate at a temperature outside this range, a remote installation is recommended. The unit can operate in a location with a wide fluctuation of temperatures, but the discharge rate will vary accordingly. The benchmark operating temperature is 68°F (20°C). For example, at this temperature a number 1 dial setting is equivalent to a one month duration. Approximate average daily discharge rates and the life expectancy in months at various temperatures above and below 68°F (20°C) for the GREASOMATIC are given in the chart shown below.

**Discharge Rate Chart**

| <b>Dial Setting</b> | <b>14°F (-10°C)</b>      | <b>32°F (0°C)</b>        | <b>50°F (10°C)</b>       | <b>68°F (20°C)</b>               | <b>86°F (30°C)</b>        | <b>104°F (40°C)</b>       | <b>122°F (50°C)</b>       |
|---------------------|--------------------------|--------------------------|--------------------------|----------------------------------|---------------------------|---------------------------|---------------------------|
| <b>1</b>            | .4 strokes<br>8 months   | .8 strokes<br>4 months   | 1.6 strokes<br>2 months  | <b>3.2 strokes<br/>1 months</b>  | 6.4 strokes<br>.5 months  |                           |                           |
| <b>2</b>            | .2 strokes<br>16 months  | .4 strokes<br>8 months   | .8 strokes<br>4 months   | <b>1.6 strokes<br/>2 months</b>  | 3.2 strokes<br>1 months   | 4.8 strokes<br>.7 months  |                           |
| <b>3</b>            | .13 strokes<br>24 months | .26 strokes<br>12 months | .53 strokes<br>6 months  | <b>1.1 strokes<br/>3 months</b>  | 2.1 strokes<br>1.5 months | 3.2 strokes<br>1 months   | 4.8 strokes<br>.7 months  |
| <b>4</b>            |                          | .2 strokes<br>16 months  | .4 strokes<br>8 months   | <b>.8 strokes<br/>4 months</b>   | 1.6 strokes<br>2 months   | 2.4 strokes<br>1.3 months | 3.6 strokes<br>.9 months  |
| <b>6</b>            |                          | .13 strokes<br>24 months | .26 strokes<br>12 months | <b>.53 strokes<br/>6 months</b>  | 1.1 strokes<br>3 months   | 1.6 strokes<br>2 months   | 2.4 strokes<br>1.3 months |
| <b>8</b>            |                          |                          | .2 strokes<br>16 months  | <b>.4 strokes<br/>8 months</b>   | .8 strokes<br>4 months    | 1.2 strokes<br>2.7 months | 1.8 strokes<br>1.8 months |
| <b>12</b>           |                          |                          | .13 strokes<br>24 months | <b>.26 strokes<br/>12 months</b> | .53 strokes<br>6 months   | .8 strokes<br>4 months    | 1.2 strokes<br>2.7 months |

GREASOMATIC is a registered trademark of WYMARK, Ltd., Cheltenham, England. It is manufactured to the highest standards of quality by WYMARK, Ltd., certified under BS EN ISO 9002:1994. Because the conditions in which GREASOMATICs are used can vary so widely, no responsibility can be accepted for consequential damages beyond replacement of the GREASOMATIC or refund of amount paid.

*Distributed by:*

Ingersoll Engineering Co. Inc.  
P.O. Box 536  
Los Alamitos, California 90720  
Telephone 1.888.464.3644  
Fax 1.714.995.7720  
Email sales@greasomatic.com

*Contact your local authorized **GREASOMATIC** distributor*